

■ Features

- DIP 2"x1" package with industry standard pinout
- 8:1(9~75Vdc) ultra-wide input range
- Operating temperature range -40 ~ +90°C
- No minimum load required
- Comply to BS EN/EN55032 radiated Class A without additional components
- High efficiency up to 90%
- Protections: Short circuit (Continuous) / Overload / Over voltage / UVLO
- 3KVdc I/O isolation
- Remote ON/OFF control
- Trimming output (±10%)
- 3 years warranty

■ Applications

- Telecom/datacom system
- Wireless network
- Industrial control facility
- Instrument
- Analyzer
- Detector
- Data switch

■ GTIN CODE

MW Search: <https://www.meanwell.com/serviceGTIN.aspx>

■ Description

SKM30W8 and DKM30W8 series are 30W isolated and regulated module type DC-DC converter with DIP 2"x1" package. It features international standard pins, a high efficiency up to 90%, wide working temperature range -40~+90°C, 3KVdc I/P-O/P isolation voltage, compliance to BS EN/EN55032 radiated Class A without additional components, continuous-mode short circuit, overload, over voltage, input under voltage protection, remote ON/OFF and trimmable output voltage etc. The models account for 9~75Vdc 8:1 ultra-wide input range, and various output voltage, 3.3V/5V/12V/15V/24V for single output and ±12V/±15V for dual outputs, which are suitable for all kinds of systems, such as industrial control, telecommunication field, distributed power architecture, and so on.

■ Model Encoding

S **KM** **30W8** - **12**

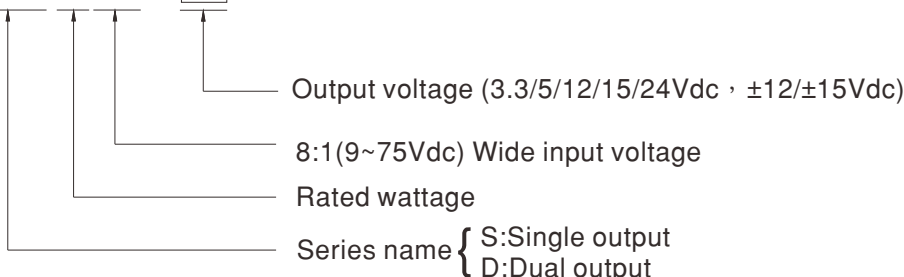



30W 2"x1" Package 8:1 Ultra-Wide Input DC-DC Regulated Converter

SKM30W8 & DKM30W8 series

MODEL SELECTION TABLE							
ORDER NO.	INPUT			OUTPUT		EFFICIENCY (TYP.)	CAPACITOR LOAD (MAX.)
	INPUT VOLTAGE (RANGE)	INPUT CURRENT		OUTPUT VOLTAGE	OUTPUT CURRENT		
		NO LOAD	FULL LOAD				
SKM30W8-03	Nominal 12V, 24V, 36V, 48V, 72V (9 ~ 75V)	15mA	1119mA	3.3V	0~7000mA	87%	680μF
SKM30W8-05		15mA	1437mA	5V	0~6000mA	87%	680μF
SKM30W8-12		15mA	1420mA	12V	0~2500mA	89%	330μF
SKM30W8-15		15mA	1420mA	15V	0~2000mA	90%	220μF
SKM30W8-24		15mA	1420mA	24V	0~1250mA	89%	100μF
DKM30W8-12		15mA	1420mA	±12V	±0~1250mA	89%	*150μF
DKM30W8-15		15mA	1420mA	±15V	±0~1000mA	90%	*100μF

* For each output

SPECIFICATION

INPUT			
VOLTAGE RANGE	9~75Vdc		
SURGE VOLTAGE (100ms max.)	100Vdc		
FILTER	Pi type		
PROTECTION	Fuse recommended 8A Slow-Blow		
OUTPUT			
VOLTAGE ACCURACY	±2% max.		
RATED POWER	30W		
RIPPLE & NOISE	Note.2	3.3 ~ 15Vo: 150mVp-p, 24Vo: 240mVp-p	
LINE REGULATION	Note.3	±0.2%	
LOAD REGULATION	Note.4	±1% for 3.3Vo model, ±0.5% for other models	
CROSS REGULATION	±5% @ 25% ~ 100% load only dual output		
SWITCHING FREQUENCY (Typ.)	200KHz		
EXTERNAL TRIM ADJ. RANGE (Typ.)	±10% (Single output model only)		
PROTECTION			
SHORT CIRCUIT	Continuous, automatic recovery		
OVERLOAD	110 ~ 190%		
	Protection type : Recovers automatically after fault condition is removed		
OVER VOLTAGE	Clamp by TVS diodes		
UNDER VOLTAGE LOCKOUT (Typ.)	Start-up voltage	8.8Vdc	
	Shutdown voltage	7.5Vdc	
FUNCTION			
REMOTE CONTROL	Power ON: R.C. ~ -Vin >2.5~75Vdc or open circuit ; Power OFF: R.C. ~ -Vin <1Vdc or short		
ENVIRONMENT			
COOLING	Free-air convection		
WORKING TEMP.	-40 ~ +90°C (Refer to "Derating Curve")		
CASE TEMPERATURE	+110°C max.		
WORKING HUMIDITY	5% ~ 95% RH non-condensing		
STORAGE TEMP., HUMIDITY	-55 ~ +125°C, 10 ~ 95% RH non-condensing		
TEMP. COEFFICIENT	±0.03% / °C (0 ~ 60°C)		
SOLDERING TEMPERATURE	1.5mm from case of 3 ~ 5sec./265°C max.		
VIBRATION	10 ~ 500Hz, 2G 10min./1cycle, period for 60min. each along X, Y, Z axes		
SAFETY & EMC (Note.5)			
SAFETY STANDARDS	EAC TP TC 020/2011 approved		
WITHSTAND VOLTAGE	I/P-O/P:3KVdc		
ISOLATION RESISTANCE	I/P-O/P:100M Ohms / 500Vdc / 25°C / 70% RH		
ISOLATION CAPACITANCE (Typ.)	1000pF		
EMC EMISSION	Parameter	Standard	Test Level / Note
	Conducted	BS EN/EN55032(CISPR32)	N/A
	Radiated	BS EN/EN55032(CISPR32)	Class A without additional components Class B with additional components
EMC IMMUNITY	Parameter	Standard	Test Level / Note
	ESD	BS EN/EN61000-4-2	Level 2, ±4KV contact
	Radiated Susceptibility	BS EN/EN61000-4-3	Level 2, 3V/m
	EFT/Bursts	BS EN/EN61000-4-4	Level 1, 0.5KV
	Surge	BS EN/EN61000-4-5	Level 2, ±0.5KV Line-Line
	Conducted	BS EN/EN61000-4-6	Level 2, 3V(e.m.f.)
	Magnetic Field Immunity	BS EN/EN61000-4-8	Level 1, 1A/m
OTHERS			
MTBF	>500Khrs MIL-HDBK-217F(25°C)		
DIMENSION (L*W*H)	50.8*25.4*11.2mm (2*1*0.44 inch)		
CASE MATERIAL	Six-side shielded case		
PACKING	33g ; 10pcs/per tube, 400pcs/40 tube/per carton		

NOTE

- All parameters are specified at normal input (24Vdc), rated load, 25°C 70% RH ambient.
- Ripple & noise are measured at 20MHz by using a 12" twisted pair terminated with a 0.1µf & 47µf capacitor.
- Line regulation is measured from low line to high line at rated load.
- Load regulation is measured from 0% to 100% rated load.
- The final equipment must be re-confirm that it still meet EMC directives. For guidance on how to perform these EMC tests, please refer to "EMI testing of component power supplies."(as available on <http://www.meanwell.com>)

 ※ Product Liability Disclaimer : For detailed information, please refer to <https://www.meanwell.com/serviceDisclaimer.aspx>

■ Derating Curve

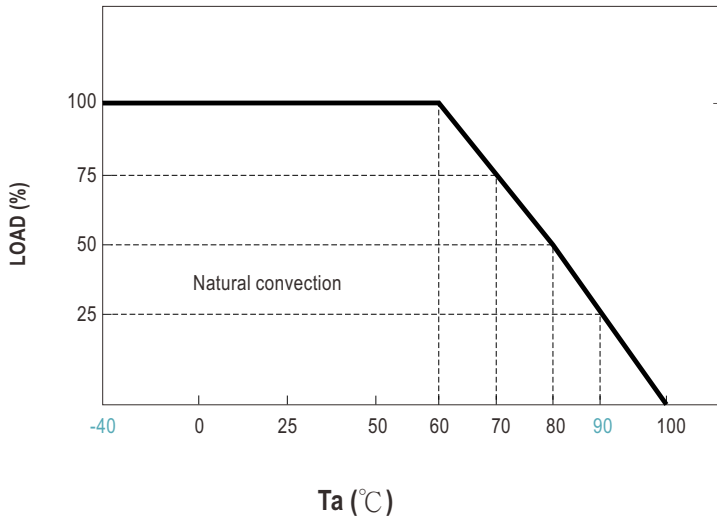

■ EMC Suggestion Circuit

※ Required external components to meet BS EN/EN55032 radiated Class B emission are as below:

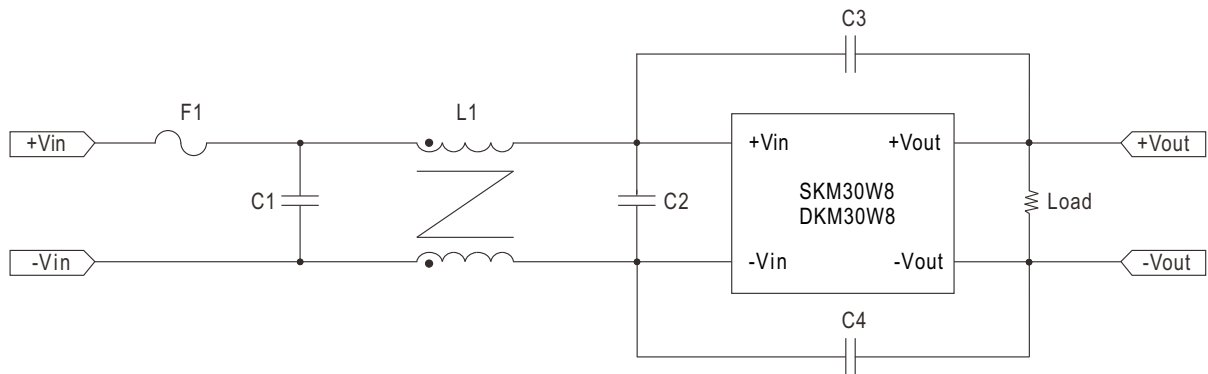

Model No.	BS EN/EN55032 radiated Class B					
	F1	C1	C2	C3	C4	L1
SKM30W8 DKM30W8	Suggest 8A Slow-Blow Type	47 μ F/100V	2.2 μ F/50V 1210 MLCC	1000pF/5KV MLCC	1000pF/5KV MLCC	325 μ H Common Choke

Note : Choose according to actual input current for F1

External Output Trimming

In order to trim the voltage up or down one needs to connect the trim resistor either between the trim pin and -Vo for trim-up and between trim pin and +Vo for trim-down. This is shown in Figures 1 and 2:

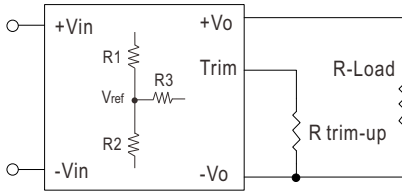

Figure 1. Trim-up Voltage Setup

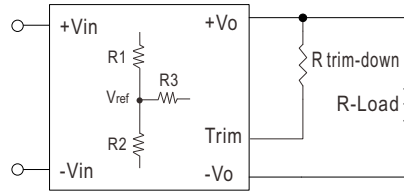

Figure 2. Trim-down Voltage Setup

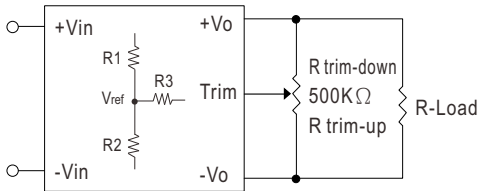

Figure 3. Trim-Connections

Table 1 – Trim up and Trim down Resistor Values

Model Number	Output Voltage(V)	R1 (KΩ)	R2 (KΩ)	R3 (KΩ)	Vref
SKM30W8-03	3.3	2.43	1.47	7.5	1.24
SKM30W8-05	5	1	1	3.9	2.5
SKM30W8-12	12	3.83	1	7.5	2.5
SKM30W8-15	15	7.5	1.5	11	2.5
SKM30W8-24	24	8.66	1	8.2	2.5

1. The value of **Rtrim - up** defined as:

$$A = \left(\frac{V_{ref}}{V_o' - V_{ref}} \right) \times R1$$

$$R_{trim - up} = \left(\frac{A \times R2}{R2 - A} \right) - R3$$

Where

R_{trim-up} is the external resistor in Kohm.

V_{o, nom} is the nominal output voltage.

V_{o'} is the desired output voltage.

R1, R2, R3 and V_{ref} are internal to the unit and defined in Table 1.

For example, to trim-up the output voltage of 12V model (SKM30W8-12) by 10% to 13.2V, R_{trim-up} is calculated as follows:

$$V_{o, nom} = 12V$$

$$V_o' = 13.2V$$

$$R1 = 3.83 K\Omega$$

$$R2 = 1 K\Omega$$

$$R3 = 7.5 K\Omega$$

$$V_{ref} = 2.5V$$

$$A = \left(\frac{2.5}{13.2 - 2.5} \right) \times 3.83 = 0.894$$

$$\begin{aligned} R_{trim - up} &= \left(\frac{0.894 \times 1}{1 - 0.894} \right) - 7.5 \\ &= \left(\frac{0.894}{0.106} \right) - 7.5 \\ &= 0.933K\Omega \end{aligned}$$

2. The value of $R_{\text{trim-down}}$ defined as:

$$A = \left(\frac{V_o' - V_{\text{ref}}}{V_{\text{ref}}} \right) \times R_2$$

$$R_{\text{trim-down}} = \left(\frac{A \times R_1}{R_1 - A} \right) - R_3$$

Where

$R_{\text{trim-down}}$ is the external resistor in Kohm.

$V_{o,\text{nom}}$ is the nominal output voltage.

V_o' is the desired output voltage.

R_1 , R_2 , R_3 and V_{ref} are internal to the unit and defined in Table 1.

For example, to trim-down the output voltage of 12V model (SKM30W8-12) by 10% to 10.8V, $R_{\text{trim-down}}$ is calculated as follows:

$$V_{o,\text{nom}} = 12\text{V}$$

$$V_o' = 10.8\text{V}$$

$$R_1 = 3.83 \text{ K}\Omega$$

$$R_2 = 1 \text{ K}\Omega$$

$$R_3 = 7.5 \text{ K}\Omega$$

$$V_{\text{ref}} = 2.5\text{V}$$

$$A = \left(\frac{10.8 - 2.5}{2.5} \right) \times 1 = 3.32$$

$$\begin{aligned} R_{\text{trim-down}} &= \left(\frac{3.32 \times 3.83}{3.83 - 3.32} \right) - 7.5 \\ &= \left(\frac{12.715}{0.15} \right) - 7.5 \\ &= 17.431\text{K}\Omega \end{aligned}$$

Mechanical Specification

- All dimensions in mm(inch)
- Tolerance:x.x, x.xx±0.5mm(x.x, x.xx±0.02")

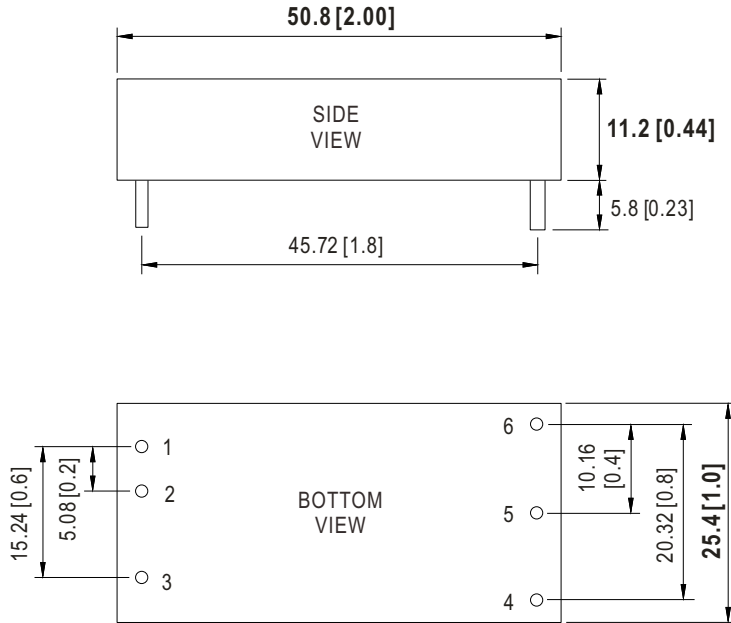

Note : Pin size tolerance $\phi 1\pm 0.1\text{mm}$

Pin Assignment

Pin-Out		
Pin No.	SKM30W8 (Single output)	DKM30W8 (Dual output)
1	+Vin	+Vin
2	-Vin	-Vin
3	R.C.	R.C.
4	Trim	-Vout
5	-Vout	Common
6	+Vout	+Vout

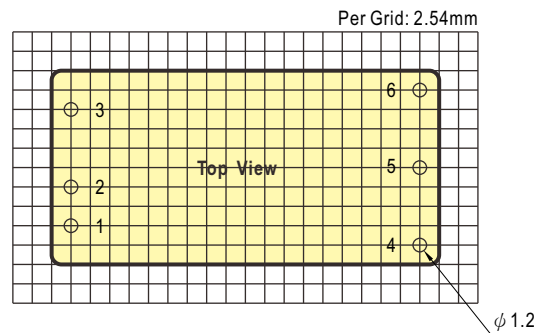

■ Packing

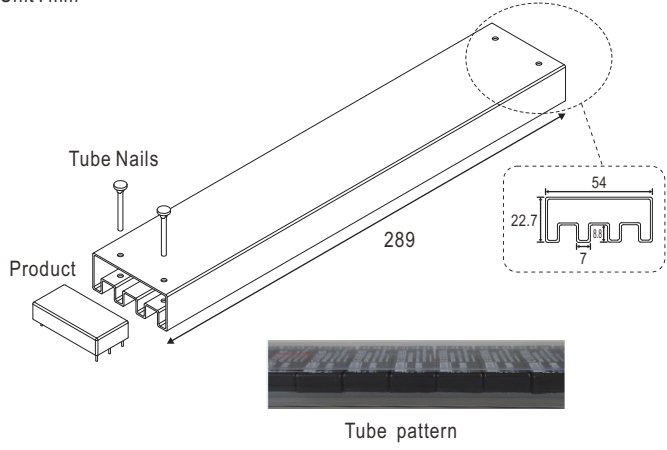
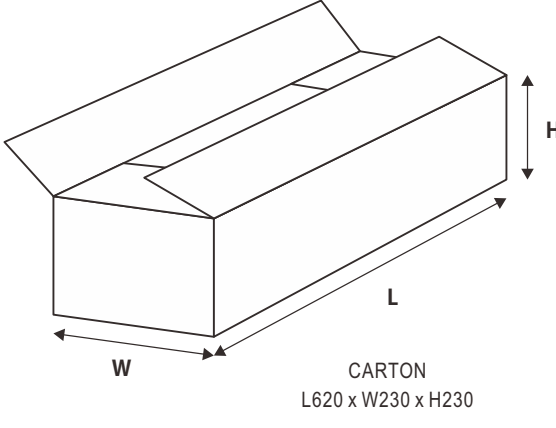
Standard Tube Packing	MPQ Per Tube (PCS)	One Tube G.W.	Max. Q'TY/ Carton(PCS)	One Carton G.W.
<p>Unit : mm</p>  <p>Tube pattern</p>  <p>CARTON L620 x W230 x H230</p>	10	418g	400	17.52Kg

■ Installation Manual

Please refer to : <http://www.meanwell.com/manual.html>