

### ■ Features

- DIP 1"x1" package with industry standard pinout
- 8:1(9~75Vdc) ultra-wide input range
- Operating temperature range -40 ~ +90°C
- No minimum load required
- High efficiency up to 90%
- Protections: Short circuit (Continuous) / Overload / Over voltage / Over temperature / UVLO
- 1.5KVdc I/O isolation
- Remote ON/OFF control
- Trimming output ( $\pm 10\%$ )
- 3 years warranty

### ■ Applications

- Telecom/datacom system
- Wireless network
- Industrial control facility
- Instrument
- Analyzer
- Detector
- Data switch

### ■ GTIN CODE

MW Search: <https://www.meanwell.com/serviceGTIN.aspx>

### ■ Description

SKMW30W8 and DKMW30W8 series are 30W isolated and regulated module type DC-DC converter with DIP 1"x1" package. It features international standard pins, a high efficiency up to 90%, wide working temperature range -40~+90°C, 1.5KVdc I/P-O/P isolation voltage, continuous-mode short circuit, overload, over voltage, input under voltage protection, remote ON/OFF and trimmable output voltage etc. The models account for 9~75Vdc 8:1 ultra-wide input range, and various output voltage, 3.3V/5V/12V/15V for single output and  $\pm 12V/\pm 15V$  for dual outputs, which are suitable for all kinds of systems, such as industrial control, telecommunication field, distributed power architecture, and so on.

### ■ Model Encoding

**S** **KMW30W8** - **12**

Output voltage (3.3/5/12/15Vdc ,  $\pm 12/\pm 15Vdc$ )

8:1(9~75Vdc) Wide input voltage

Rated wattage

Series name { S:Single output  
D: Dual output



30W 1"x1" Package 8:1 Ultra-Wide Input DC-DC Regulated Converter

SKMW30W8 & DKMW30W8 series

MODEL SELECTION TABLE							
ORDER NO.	INPUT			OUTPUT		EFFICIENCY (TYP.)	CAPACITOR LOAD (MAX.)
	INPUT VOLTAGE (RANGE)	INPUT CURRENT		OUTPUT VOLTAGE	OUTPUT CURRENT		
		NO LOAD	FULL LOAD				
SKMW30W8-03	Nominal 12V, 24V, 36V, 48V, 72V (9 ~ 75V)	10mA	1172mA	3.3V	0~7500mA	85%	7000 $\mu$ F
SKMW30W8-05		10mA	1400mA	5V	0~6000mA	87%	6000 $\mu$ F
SKMW30W8-12		10mA	1404mA	12V	0~2500mA	87.5%	2500 $\mu$ F
SKMW30W8-15		10mA	1404mA	15V	0~2000mA	90%	2000 $\mu$ F
DKMW30W8-12		10mA	1425mA	$\pm$ 12V	$\pm$ 0~1250mA	89%	*1250 $\mu$ F
DKMW30W8-15		10mA	1425mA	$\pm$ 15V	$\pm$ 0~1000mA	88.5%	*1000 $\mu$ F

\* For each output

**SPECIFICATION**

INPUT			
VOLTAGE RANGE	9~75Vdc		
SURGE VOLTAGE (100ms max.)	100Vdc		
FILTER	Pi network		
PROTECTION	Fuse recommended. 6A delay time Type		
OUTPUT			
VOLTAGE ACCURACY	±1.5%		
RATED POWER	30W		
RIPPLE & NOISE	Note.2	150mVp-p	
LINE REGULATION	Note.3	±0.5%	
LOAD REGULATION	Note.4	Single output models: ±0.5%, Dual output models: ±1%	
CROSS REGULATION	±5% @ 25% ~ 100% load only dual output		
SWITCHING FREQUENCY (Typ.)	Single output models: 270KHz, Dual output models: 330KHz		
EXTERNAL TRIM ADJ. RANGE (Typ.)	±10% (Single output model only)		
PROTECTION			
SHORT CIRCUIT	Continuous, automatic recovery		
OVERLOAD	110 ~ 200% rated output power		
	Protection type : Recovers automatically after fault condition is removed		
OVER VOLTAGE	Clamp by zener diode		
OVER TEMPERATURE	Shut down o/p voltage, recovers automatically after temperature goes down		
UNDER VOLTAGE LOCKOUT (Typ.)	Start-up voltage: 8.5Vdc		
	Shutdown voltage: 8Vdc		
FUNCTION			
REMOTE CONTROL	Power ON: R.C. ~ -Vin >3.5~75Vdc or open circuit ; Power OFF: R.C. ~ -Vin <1Vdc or short		
ENVIRONMENT			
COOLING	Free-air convection		
WORKING TEMP.	-40 ~ +90°C (Refer to "Derating Curve")		
CASE TEMPERATURE	+105°C max.		
WORKING HUMIDITY	20% ~ 90% RH non-condensing		
STORAGE TEMP., HUMIDITY	-55 ~ +125°C, 10 ~ 95% RH non-condensing		
TEMP. COEFFICIENT	±0.03% / °C (0 ~ 55°C)		
SOLDERING TEMPERATURE	1.5mm from case of 1 ~ 3 sec./260°C max.		
VIBRATION	10 ~ 500Hz, 2G 10min./1cycle, period for 60min. each along X, Y, Z axes		
SAFETY & EMC (Note.5)			
SAFETY STANDARDS	EAC TP TC 020/2011 approved		
WITHSTAND VOLTAGE	I/P-O/P:1.5KVdc		
ISOLATION RESISTANCE	I/P-O/P:100M Ohms / 500Vdc / 25°C / 70% RH		
ISOLATION CAPACITANCE (Typ.)	1500pF		
EMC EMISSION	Parameter	Standard	Test Level / Note
	Conducted	BS EN/EN55032(CISPR32)	Class A with additional components
	Radiated	BS EN/EN55032(CISPR32)	Class A with additional components
EMC IMMUNITY	Parameter	Standard	Test Level / Note
	ESD	BS EN/EN61000-4-2	Level 3, ±8KV air, Level 2, ±4KV contact
	Radiated Susceptibility	BS EN/EN61000-4-3	Level 2, 3V/m
	EFT/Bursts	BS EN/EN61000-4-4	Level 1, 0.5KV
	Surge	BS EN/EN61000-4-5	Level 2, Line-Line 0.5KV
	Conducted	BS EN/EN61000-4-6	Level 2, 3V
	Magnetic Field	BS EN/EN61000-4-8	Level 2, 3A/m
OTHERS			
MTBF	>1625Khrs MIL-HDBK-217F(25°C)		
DIMENSION (L*W*H)	25.4*25.4*10.2mm (1*1*0.4 inch)		
CASE MATERIAL	Six-sided shield metal case		
PACKING	22.5g ; 12pcs/per tube, 600pcs/50 tube/per carton		

**NOTE**

- All parameters are specified at normal input (48Vdc), rated load, 25°C 70% RH ambient.
- Ripple & noise are measured at 20MHz by using a 12" twisted pair terminated with a 0.1µf & 47µf capacitor.
- Line regulation is measured from low line to high line at rated load.
- Load regulation is measured from 0% to 100% rated load.
- The final equipment must be re-confirm that it still meet EMC directives. For guidance on how to perform these EMC tests, please refer to "EMI testing of component power supplies."(as available on <http://www.meanwell.com>)

 ※ Product Liability Disclaimer : For detailed information, please refer to <https://www.meanwell.com/serviceDisclaimer.aspx>

■ Derating Curve

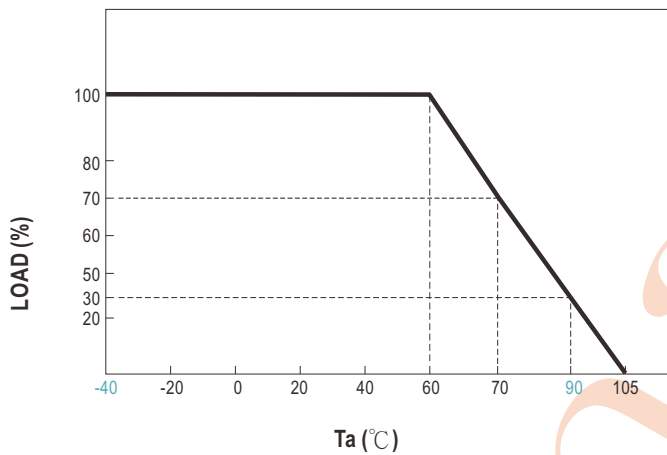

■ Input Voltage VS Derating Curve

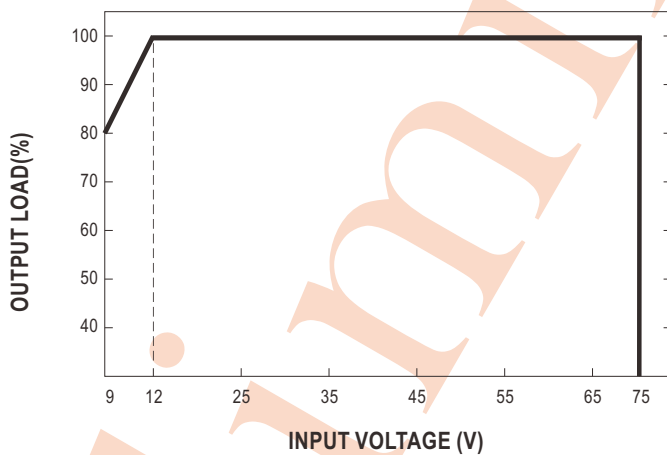

■ EMC Suggest Circuit

※ Required external componets to meet BS EN/EN55032 conducted/radiated Class A emission as below:

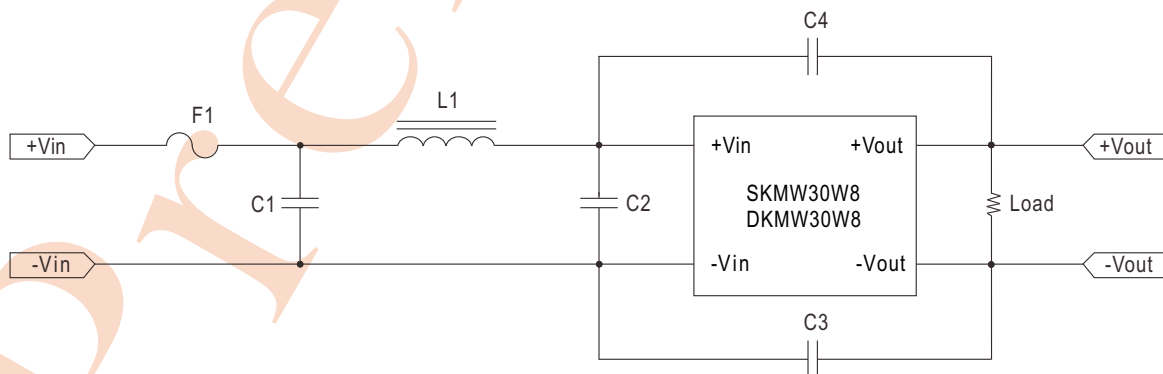

Model No.	BS EN/EN55032 conducted/radiated Class A			
	F1	C1,C2	C3,C4	L1
SKMW30W8 DKMW30W8	Suggest 6A delay time Type	2.2μF/100V	1000pF/2KV	10μH

### External Output Trimming

In order to trim the voltage up or down one needs to connect the trim resistor either between the trim pin and -Vo for trim-up and between trim pin and +Vo for trim-down. The output voltage trim range is ±10%. This is shown in Figures 1 and 2:

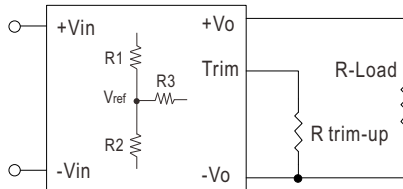

Figure 1. Trim-up Voltage Setup

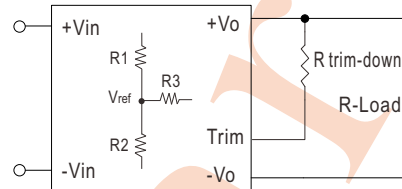

Figure 2. Trim-down Voltage Setup

#### 1. The value of Rtrim-up defined as:

$$R_{trim-up} = \left( \frac{V_r \times R1 \times (R2 + R3)}{(V_o - V_{o, nom}) \times R2} \right) - R_t \text{ (K}\Omega\text{)}$$

Where

R<sub>trim-up</sub> is the external resistor in Kohm.

V<sub>o, nom</sub> is the nominal output voltage.

V<sub>o</sub> is the desired output voltage.

R1, R<sub>t</sub>, R2, R3 and V<sub>r</sub> are internal to the unit and are defined in Table 1.

Table 1 – Trim up and Trim down Resistor Values

Model Number	Output Voltage(V)	R1 (KΩ)	R2 (KΩ)	R3 (KΩ)	R <sub>t</sub> (KΩ)	V <sub>ref</sub>
SKMW30W8-03	3.3	2.74	1.8	0.249	9.1	1.24
SKMW30W8-05	5	2.32	2.32	0	8.2	2.5
SKMW30W8-12	12	6.8	2.4	2.32	22	2.5
SKMW30W8-15	15	8.06	2.4	3.9	27	2.5

For example, to trim-up the output voltage of 5.0V module (SKMW30W8-05) by 10% to 5.5V, R<sub>trim-up</sub> is calculated as follows:

$$V_o - V_{o, nom} = 5.5 - 5.0 = 0.5V$$

$$R1 = 2.32 \text{ K}\Omega$$

$$R2 = 2.32 \text{ K}\Omega$$

$$R3 = 0 \text{ K}\Omega$$

$$R_t = 8.2 \text{ K}\Omega$$

$$V_r = 2.5V$$

$$R_{trim-up} = \left( \frac{2.5 \times 2.32 \times (2.32+0)}{0.5 \times 2.32} \right) - 8.2 = 3.4 \text{ (K}\Omega\text{)}$$

#### 2. The value of Rtrim-down defined as:

$$R_{trim-down} = R1 \times \left( \frac{V_r \times R1}{(V_{o, nom} - V_o) \times R2} - 1 \right) - R_t \text{ (K}\Omega\text{)}$$

Where

R<sub>trim-down</sub> is the external resistor in Kohm.

V<sub>o, nom</sub> is the nominal output voltage.

V<sub>o</sub> is the desired output voltage.

R1, R<sub>t</sub>, R2, R3 and V<sub>r</sub> are internal to the unit and are defined in Table 1.

For example, to trim-down the output voltage of 5.0V module (SKMW30W8-05) by 10% to 4.5V, R<sub>trim-down</sub> is calculated as follows:

$$V_{o, nom} - V_o = 5.0 - 4.5 = 0.5V$$

$$R1 = 2.32 \text{ K}\Omega$$

$$R2 = 2.32 \text{ K}\Omega$$

$$R3 = 0 \text{ K}\Omega$$

$$R_t = 8.2 \text{ K}\Omega$$

$$V_r = 2.5V$$

$$R_{trim-down} = 2.32 \times \left( \frac{2.5 \times 2.32}{0.5 \times 2.32} - 1 \right) - 8.2 = 1.08 \text{ (K}\Omega\text{)}$$

**Mechanical Specification**

- All dimensions in mm (inch)
- Tolerance:  $x.x \pm 1\text{mm}$  ( $x.x \pm 0.04"$ ),  $x.xx \pm 0.25\text{mm}$  ( $x.xx \pm 0.01"$ )
- Pin size is  $1 \pm 0.1\text{mm}$  ( $0.04" \pm 0.004"$ )

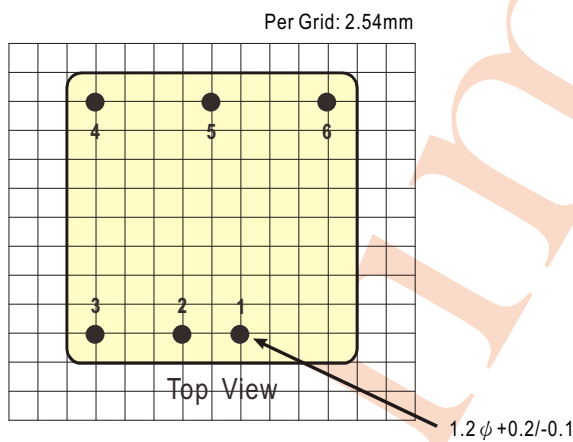
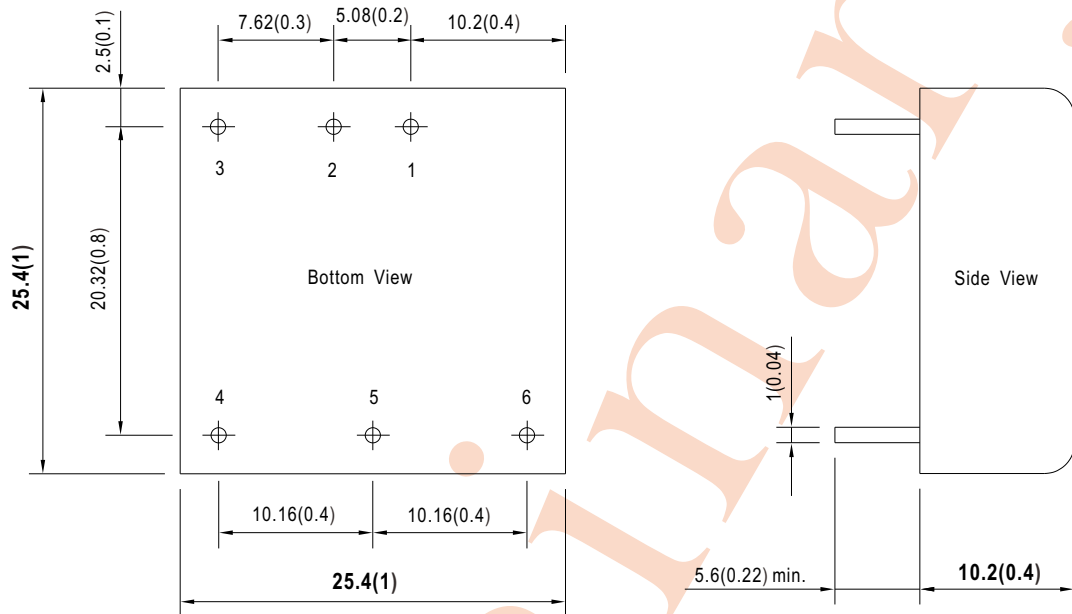

**Pin Assignment**

Pin-Out		
Pin No.	SKMW30W8 (Single output)	DKMW30W8 (Dual output)
1	+Vin	+Vin
2	-Vin	-Vin
3	R.C.	R.C.
4	-Vout	-Vout
5	Trim	Common
6	+Vout	+Vout

■ Packing

Standard Tube Packing	MPQ Per Tube (PCS)	One Tube G.W.	Max. Q'TY/ Carton(PCS)	One Carton G.W.
<p>Unit : mm</p> <p>CARTON L390.9 x W284.8 x H175.7</p>	12	306g	600	15.6Kg

■ Installation Manual

Please refer to : <http://www.meanwell.com/manual.html>